

# PHANTOM-S

PHANTOM-S – alarm-based optical turnstile with no flaps.

Just 110 mm wide cabinets, absence of flaps and various lane width (550 – 1000 mm) makes Phantom-S one of the most space saving solutions which allows to arrange easy and comfortable passage through the turnstile.

In case of unauthorized passage detected, the security service will get an alarm from the turnstile to prevent this.

A perfect balance of style, performance and security.



## OPTICAL ULTRASLIM SPEED GATES PHANTOM-S

### FOR FACILITIES WITH INTENSIVE VISITORS FLOW

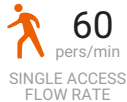

#### Key features:

- Safety sensors system allows detecting the passage of person with luggage, or arranging a free exit without necessity of identification;
- Elegant cabinets equipped with integrated LED lighting to display access status and card reader area;
- Same dimensions of cabinet for normal (550 mm) and wide lane (1000 mm);

- Low power consumption;
- Availability of integration with any access control system;
- Easy installation and maintenance;
- The ability to customize cabinet and top lid design as per project requirements;



**Technical Specifications:**

Model	Phantom-S 550	Phantom-S 1000
Cabinet width, mm		114
Cabinet length, mm		1004
Cabinet height, mm		1014
Passage width, mm	550	1000
Emergency mode (fire-alarm)		Free entry/exit
Power fail		Fail safe

**Electrical Specifications:**

Maximum power consumption, W	160
Voltage	From the AC (100-240)V, 50/60Hz; from a DC source 12 V
Indication	DotLights®, RFIDLights®, EdgeLights® FloorLights®

**Finishing**

Standard housing	Brushed SS AISI 304
Available housing	Brushed SS AISI 316; Polished SS AISI 304; Polished SS AISI 316; Powder coated RAL

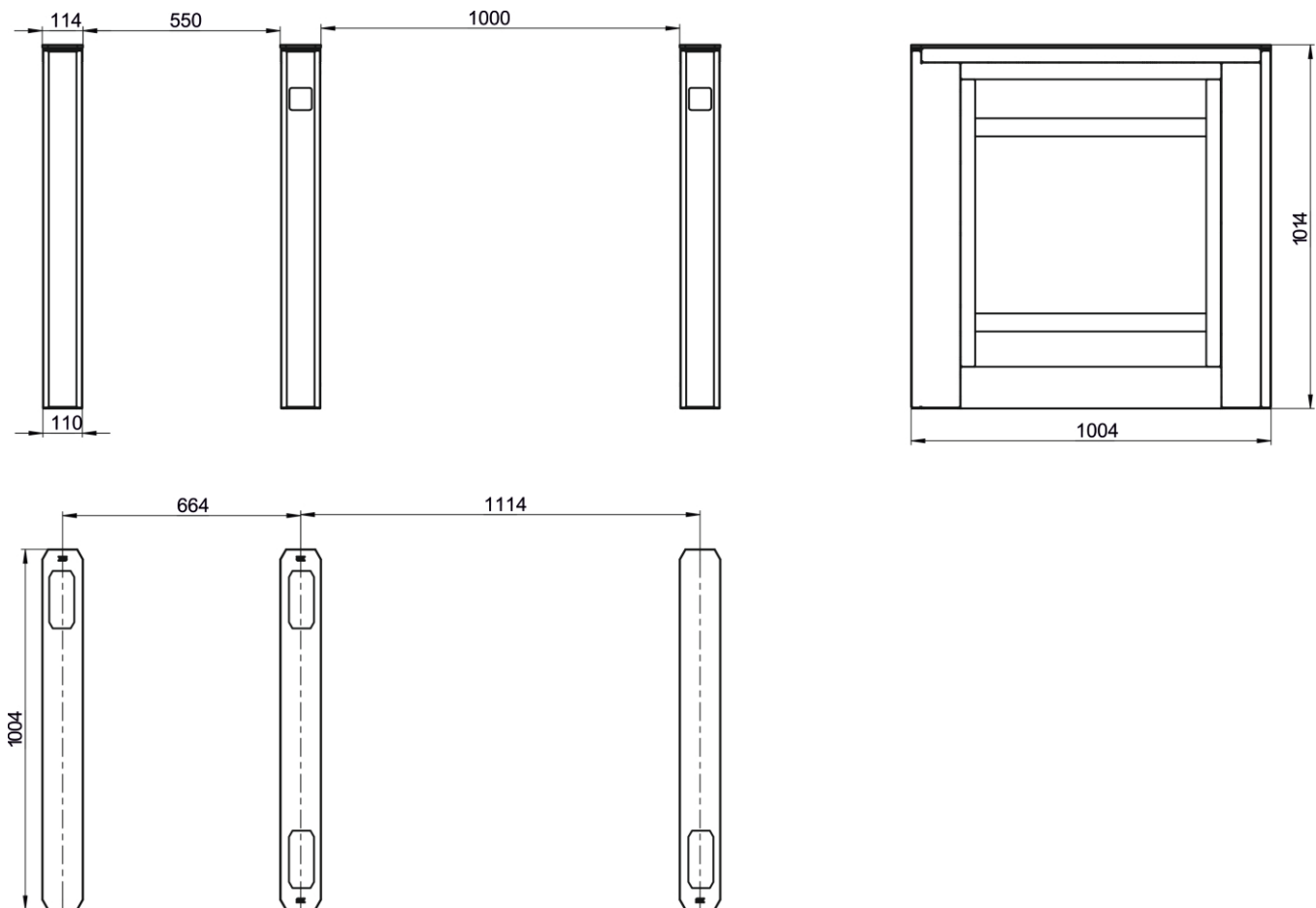

Dimensions for solid glass top lid

Specifications are subject to change without prior notice.



www.tiso.global  
 +380 (44) 291-21-11  
 e-mail: sales@tiso.global

